



ZIS359
IL 377
EDIZ. 10/09/2018

MR2

I

**MODULO RICEVITORE AD
INNESTO PER CENTRALI DI
COMANDO V2**

GB

**PLUG-IN RECEIVING MODULE
FOR
V2 CONTROL UNITS**

F

**MODULE RÉCEPTEUR
EMBROCHABLE POUR
ARMOIRES DE COMMANDE V2**

E

**MÓDULO RECEPTOR DE
CONEXIÓN PARA CUADROS DE
MANIOBRAS V2**

P

**MÓDULO RECEPTOR DE
ENCAIXE PARA QUADROS
ELÉTRICOS V2**

D

**EMPFÄNGER- STECKMODUL
FÜR V2- STEUERUNGEN**

NL

**PLUG-IN ONTVANGER
MODULE VOOR V2
BESTURINGSEENHEDEN**

RU

**МОДУЛЬ ПРИЕМА ПЛАГИНОВ
ДЛЯ БЛОКА УПРАВЛЕНИЯ V2**

P1

L1

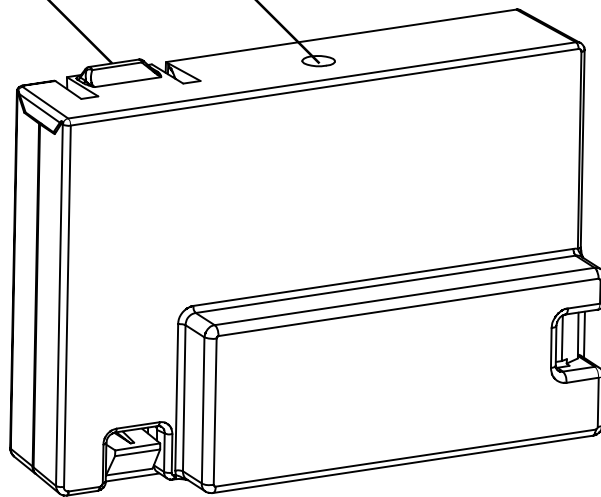

SELECTION OF THE RECEIVER CHANNEL

1. Press P1 push-button of the receiver: L1 led switches on.
2. Release the push-button, the led switches off and it sends out a sequence of single flashings for 5 seconds: the number of short flashings shows the selected channel.
3. To select the further channels press and release the P1 push-button within 5 seconds, the led changes type of flashing according to the following table:

SELECTED CHANNEL	N° IMPULSES P1	N° Flashing			
		1	2	3	4
CHANNEL 1	1	•			
CHANNEL 2	2		•		
CHANNEL 3	3			•	
CHANNEL 4	4				•

PROGRAMMING OF THE MONOSTABLE FUNCTION

WARNING: If the transmitter is ROYAL, before starting programming, set the desired code on the transmitter. Set the same code on all transmitters.

1. Select the channel of the receiver to be programmed
2. Within 5 seconds, press and hold the button on the remote control.
 - if the remote control unit is a ROYAL version, the procedure ends at point 3
 - if the remote control unit is a PERSONAL PASS version, go to point 4 and follow the procedure until the end of the section
3. The LED of the receiver goes off and goes on again for 5 seconds. After 5 second the led goes off: the receiver is ready to be used
4. The led of the receiver goes out and goes on again: the code has been memorised and the receiver remains standby for 5 s with a new code to be memorised
5. Memorise all the remote control units necessary
6. After 5 seconds without a valid transmission, the led is turned off and the receiver returns to normal operating mode

PROGRAMMAZIONE DELLA FUNZIONE BISTABILE (ROYAL system only)

WARNING: before starting programming, set the desired code on the transmitter. Set the same code on all transmitters.

1. Select the channel of the receiver to be programmed
2. Within 5 seconds, press and hold the button on the remote control
3. The LED of the receiver goes off and then goes on again: press the pushbutton P1 of the receiver within 5 sec
4. Led starts a sequence of flashings at low speed (1 flash per second)
5. After the thirtieth flash the led L1 remains on for 5 seconds
6. Press and release the pushbutton P1 within 5 seconds
7. The LED goes off: the receiver is ready to be used

PROGRAMMAZIONE DELLA FUNZIONE TIMER (ROYAL system only)

WARNING: before starting programming, set the desired code on the transmitter. Set the same code on all transmitters.

1. Select the channel of the receiver to be programmed
2. Within 5 seconds, press and hold the button on the remote control
3. The LED of the receiver goes off and then goes on again: press the pushbutton P1 of the receiver within 5 seconds
4. Led L1 starts a sequence of flashings at low speed (1 flash per second). The number of flashing corresponds to the time which can be set as shown in the table.

N° Flashing	Time
1	01 sec.
2	02 sec.
3	03 sec.
4	04 sec.
5	05 sec.
6	06 sec.
7	07 sec.
8	08 sec.
9	09 sec.
10	10 sec.
11	11 sec.
12	12 sec.
13	13 sec.
14	14 sec.
15	15 sec.
16	30 sec.

N° Flashing	Time
17	1 min.
18	1,5 min.
19	2 min.
20	2,5 min.
21	3 min.
22	3,5 min.
23	4 min.
24	4,5 min.
25	5 min.
26	5,5 min.
27	6 min.
28	6,5 min.
29	7 min.
30	7,5 min.
31	BISTABLE

5. Count the number of led L1 flashings corresponding to the time you wish to set. Press the RX button P1 during the wished flashing.
6. The sequence of flashings stops and led L1 goes off: the receiver is ready to be used.

REMOTE RADIO LEARNING

(Personal Pass system only)

This procedure allows to memorize new transmitters by radio, in sequence and without removing the receiver from the installation.

The transmitter which allows to enable the programming by radio must be memorized in advance.

The keys of all the transmitters saved in the memory via radio will have the same logic as for those of the transmitter that enabled programming.

Therefore, if the transmitter that activated programming has key 1 saved only, the new transmitters can only be saved using key 1.

1. Press for at least 5 seconds the keys 1+2 or 1+3 of one transmitter that is already saved
2. Release both keys
3. Press, within 5 seconds, the key of the new transmitter that you intend to save
4. Release the key and repeat the procedure for the other keys of the remote control or with other radio controls to be saved

SUBSTITUTIVE TRANSMITTER

(Personal Pass system only)

The substitutive transmitter, generated only by means of WINPPCL, allows to replace by radio a transmitter stored in the receiver.

A single transmission with the specially programmed SUBSTITUTIVE TX, nearby the receiver, replaces the transmitter code with the new one without removing the receiver from the installation.

Three code substitutions are permitted, if transmitter TX A is memorised, the options are:

- TX B replaces TX A (TX A is no longer operative)
- TX C replaces TX B (TX B-A is no longer operative)
- TX D replaces TX C (TX C-B-A is no longer operative)

ROLLING CODE MODE

(Personal Pass system only)

The receiver manages the rolling code for the Personal Pass system. This function is disabled by default. Rolling code mode may be activated by WinPPCL or by using the P1 programming button.

1. Press P1 push-button, holding it for 8 seconds
2. The led will switch on after 8 seconds. Release the push-button
3. The led starts a sequence of flashing for 5 seconds:
 - Single flashings → ROLLING CODE disabled
 - Double flashings → ROLLING CODE enabled
 - Triple flashings → ROLLING CODE enabled
+ cloned code erasing
4. To modify the parameters press the P1 push-button within 5 seconds after the first flashing of the sequence; the led will flash according to the new parameters.
5. After 5 seconds, the led turns off and the receiver moves back to normal operation

PROGRAMMING LOCK

(Personal Pass system only)

The PROGRAMMING LOCK function can be done only by means of WINPPCL. This function inhibits to programme again the receiver, either with P1 key or by radio. The receiver can be programmed again only by means of WINPPCL.

FULL CODE ERASING

To perform a full code erasing do the following:

1. Switch off the power supply of the control unit where the MR2 receiver is connected.
2. By holding the key P1 of the receiver pressed, you will reactivate the power supply.
The receiver LED goes on: release the P1 key
3. The memory spaces are empty and available for a new programming: the first remote control to be memorised determines the mode of operation; Royal or Personal Pass

To perform a partial code erasing the PROG2 portable programmer is required.