

**INSTALLATION
MANUAL SERIES
H600-H750**





Important information



BENITO shall not be held responsible for any damage caused to people, animals or objects derived from a misuse of the product, from applications that may exceed the limits indicated in the attached data sheet, or due to a difference use from which this product was designed.

These instructions are set out for installers, users and maintenance operators. Read the brochure carefully before installing, using or carrying out any ordinary or extraordinary maintenance. Operations that may involve risks are indicated with risk signs, as follows.

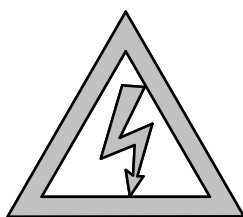

Electrocution

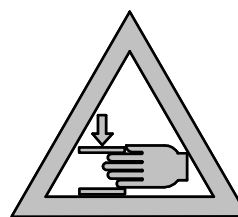

Flattening

SERIES H600-H750		
1	General safety warnings	3-4
2	General characteristics	5
3	Civil work	6-7
4	Control panel and features	8
5	Safety ties	9
6	Operation and commissioning	10-11
7	Notices of possible failures	12
8	General warnings for use	13
9	Terminal block	14
10	CE certificate	15
11	Warranty	16

1- General safety warnings

Warnings for the installer - General obligations regarding security

- 1- ATTENTION! It is extremely important, for the safety of users, to read these instructions carefully. Improper installation or improper use may cause serious damage.
- 2- Read the instructions carefully before installing the product.
- 3- The packaging materials (plastic, polystyrene, etc...) should not be left within the reach of children, since they constitute potential sources of danger, these must be deposited in containers or enclosures destined to the management and / or collection of waste.
- 4- Save the instructions for future reference.
- 5- This product has been designed and manufactured exclusively for the use indicated in this manual. Any use other than that intended could impair the operation of the product and / or represent a source of danger.
- 6- BENITO declines any responsibility derived from a misuse, improper use or different use from the intended one.
- 7- Do not install the device in explosive atmospheres, the presence of flammable gas or fumes constitutes a serious safety hazard.
- 8- In non-EU countries, in order to obtain an optimum level of safety, the guidelines mentioned above must be followed, in addition to the current national regulations.
- 9- BENITO, is not responsible for the breach of good product installation techniques supplied and their corresponding accessories as well as the deformations that could intervene in the utilization.
- 10- The installations must be carried out respecting, at all times, the existing regulations that apply to them.
- 11- Remove / disconnect the power supply before carrying out an intervention of any kind in the installation.
- 12- Place a magneto thermal protection with bipolar interruption in the electricity network, thus differential with a threshold of 0,03 Amp.
- 13- Verify that the ground installation is correctly done and connect the metal parts.
- 14- The automation has an anti crush safety device consisting of a torque control (pressure, switch) However, it is necessary to check the intervention threshold as provided in the standards indicated in point 10.
- 15- Safety devices (standard EN12978) allow the protection of possible danger areas from mechanical risks of movement, such as crush, drag, cut.
- 16- For each device it is advisable to use at least one signalling lamp (eg: flashing incorporated in the head of the bollard), as well as a signaling sign, in addition to the devices indicated in point "15").
- 17- Original Benito spare parts shall only be used when carrying out maintenance works.

1- General safety warnings

18- Benito declines all responsibility related to safety and proper functioning of the automation if non-production components for the installation which are not supplied by BENITO.

19- Do not make any changes to the components that are part of the BENITO automation system.

20- The installer must provide all information related to the manual lowering of the bollard in cas of emergency and give the user of the equipment the warning manual attached to the product.

21- Do not allow children or people to stop near the bollard during operation.

22- Keep radio controls to any other impulse emitter out of reach of children, to prevent the automation can be activated voluntarily.

23- Users can only pass over the bollard when it is completely lowered.

24- In the event of a malfunctioning, activate the disconnectors to cut off the power supply in order to free the access ("positive safety", the bollard goes down). In case a bollard it is programed as "negative safety" (bollard goes up when a power cut), the corresponding valve must also be released. The area must be signaled as "OUT OF SERVICE" and the intervention of a technician must be requested.

2- General characteristics

MODEL H600

Height from ground level	600 mm
Pylon diameter	220 mm
Drawer dimensions	300x300x830 mm
Voltage	230V 50 Hz
Consumption	600 w
Motor power	300 W (3000 r.p.m)
Speed	90 mm/s 130mm/s
Temperature range	-20°C +80°C
IP degree of protection	IP67
Rise force	1400 NW
Thickness	4 mm
Material and finish	Inox A304 satin
Rise time	4 sec.
Down time	4 sec.
Control panel	Waterlight metal cabinet I
Impact resistance	60.000 J
Security people and objects	Optional
Luminous crown	Yes (RGB 24v)
Traffic light function	Yes
Reflective band	Optional

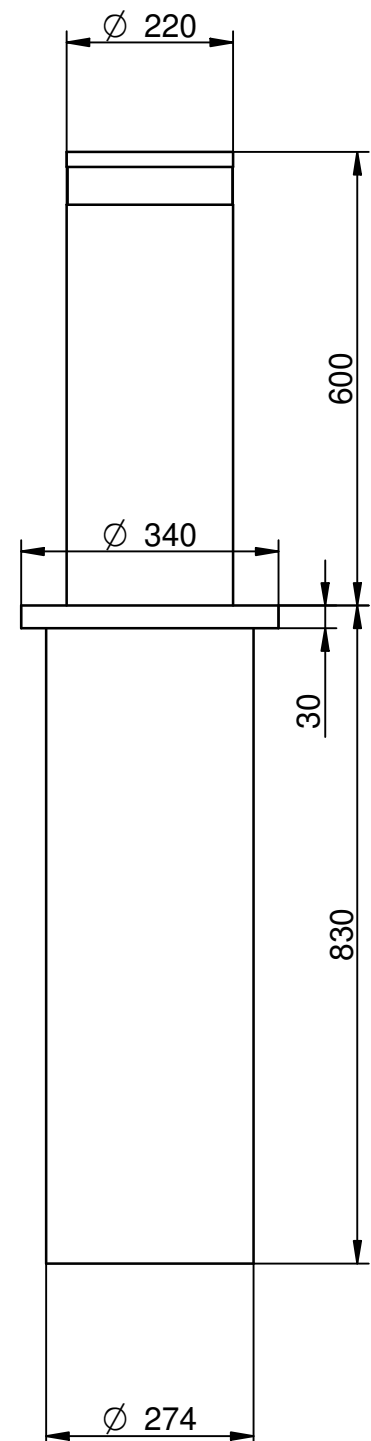

MODEL H6008

Height from ground level	600 mm
Pylon diameter	220 mm
Drawer dimensions	300x300x830 mm
Voltage	230V 50 Hz
Consumption	750 w
Motor power	300 W (3000 r.p.m)
Speed	90 mm/s 130mm/s
Temperature range	-20°C +80°C
IP degree of protection	IP67
Rise force	1400 NW
Thickness	8 mm
Material and finish	Inox A304 satin
Rise time	3-4 sec.
Down time	3-4 sec.
Control panel	Waterlight metal cabinet I
Impact resistance	250.000 KJ
Security people and objects	Optional
Luminous crown	Yes (RGB 24v)
Traffic light function	Yes
Reflective band	Optional

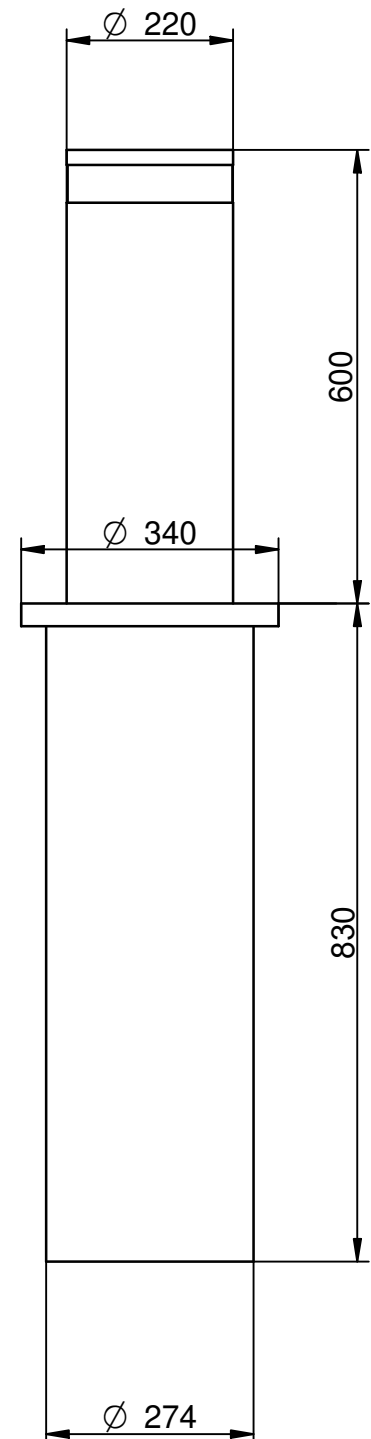

MODEL H6013

Height from ground level	600 mm
Pylon diameter	220 mm
Drawer dimensions	300x300x1060 mm
Voltage	230V 50 Hz
Consumption	750 w
Motor power	300 W (3000 r.p.m)
Speed	90 mm/s 130mm/s
Temperature range	-20°C +80°C
IP degree of protection	IP67
Rise force	1400 NW
Thickness	13 mm
Material and finish	Inox A304 satin
Rise time	3-4 sec.
Down time	3-4 sec.
Control panel	Waterlight metal cabinet I
Impact resistance	750.000 KJ
Security people and objects	Optional
Luminous crown	Yes (RGB 24v)
Traffic light function	Yes
Reflective band	Optional

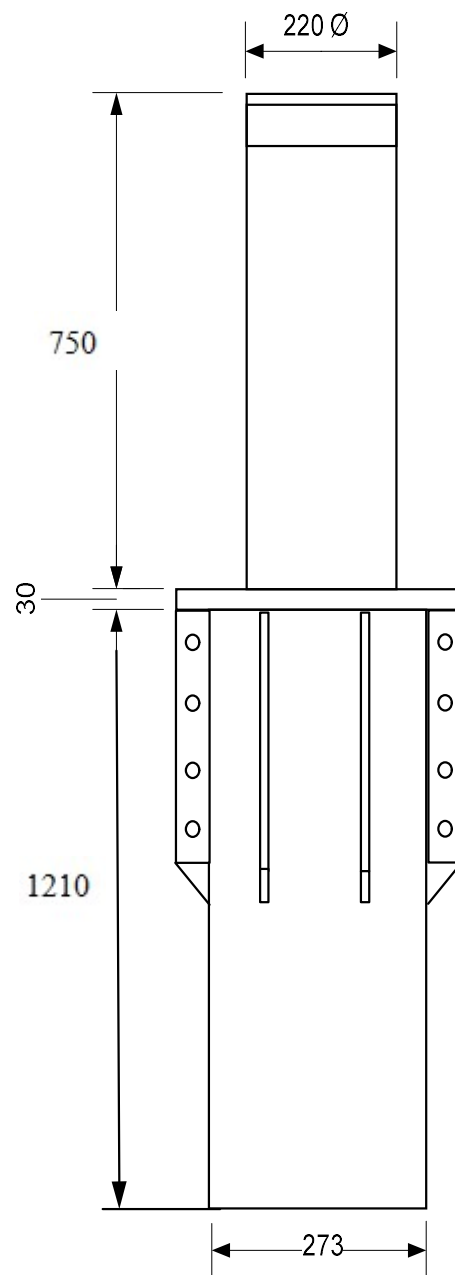

3- Civil work

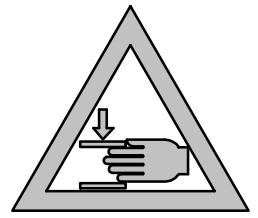

Flattening

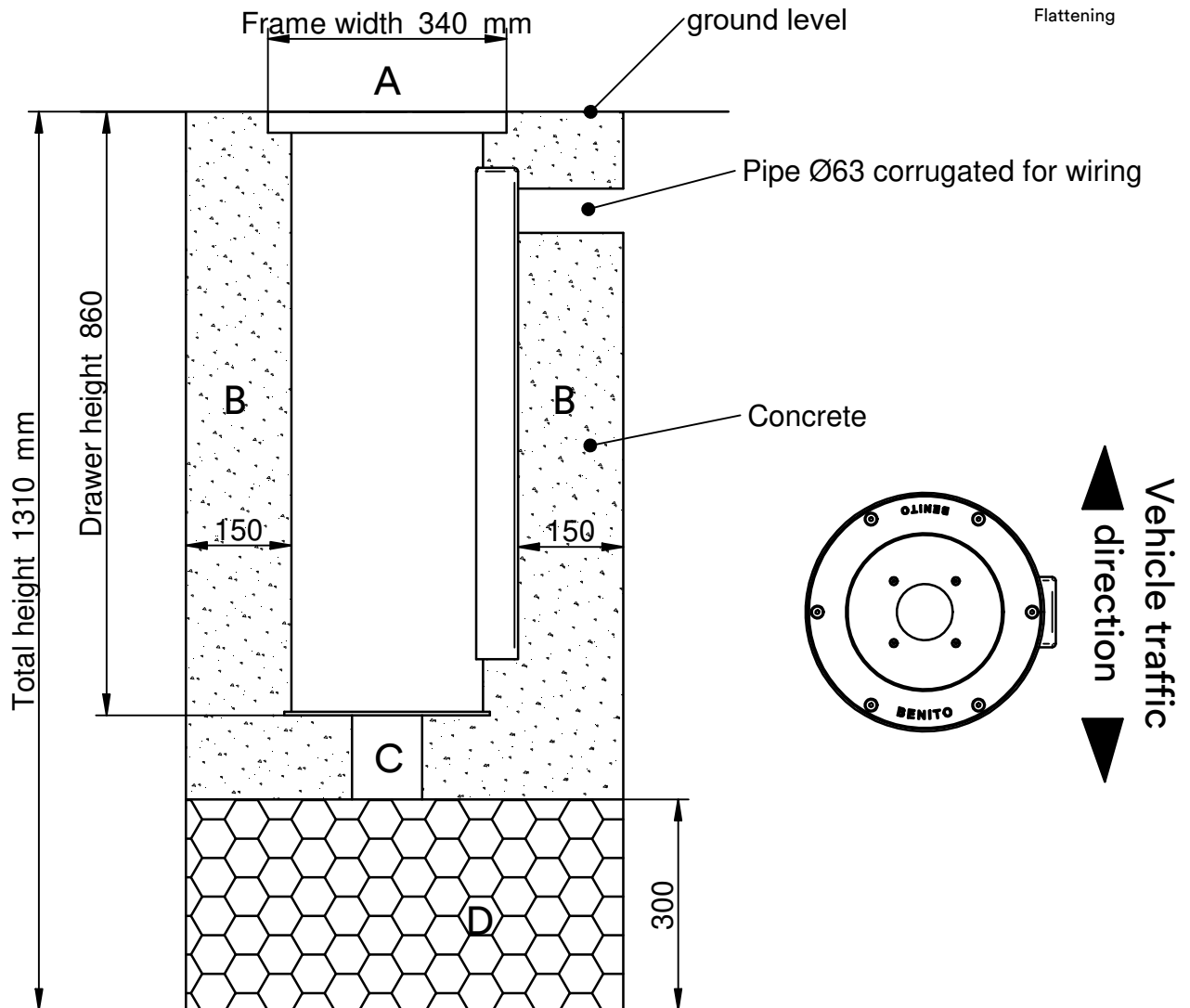

- A = Asphalt street level
- B = Concrete de 350 a 400 Kg
- C = PVC 63 mm, min.
- D = Gravel supply for drainage*

It is not possible to connect to the drainage system, a layer of gravel should be provided. Clay soil or those which prevent a natural drainage, as well as those of high phreatic level, shall be avoided.

* In case of connecting the drain to a storm sewer, it must always be through siphon connection.

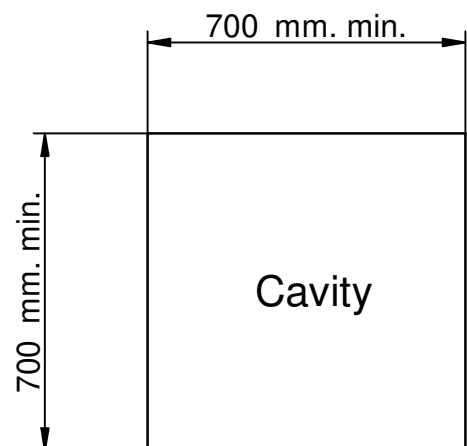

3- Civil work

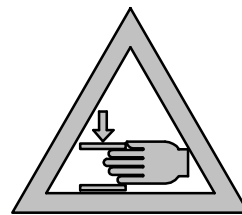

Flattening

Minimum corrugated pipe placement
Ø63mm, up to frame location, the
entrance to this will be at the bottom.

Asphalt or finishing pavement

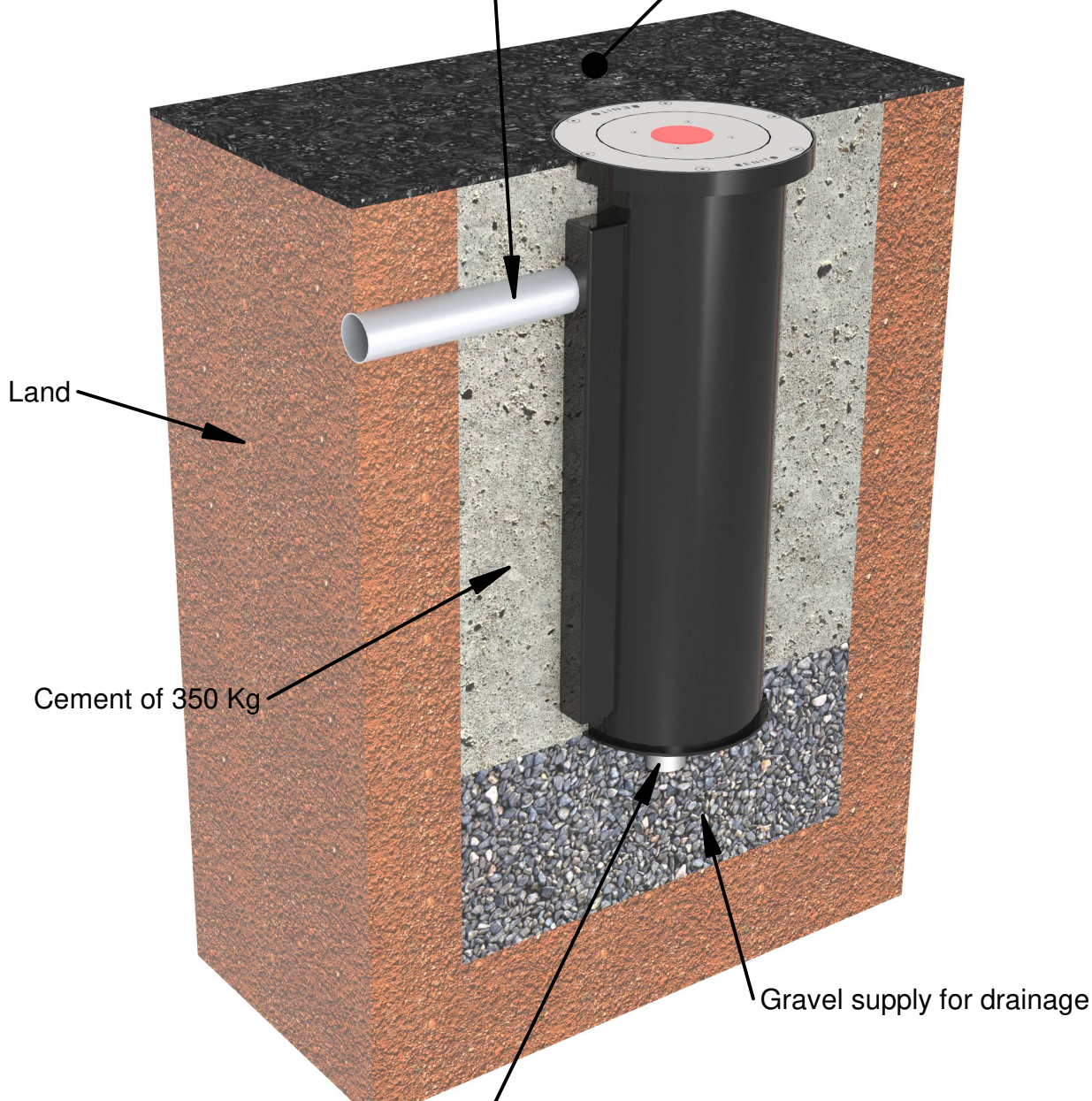

Land

Cement of 350 Kg

Gravel supply for drainage

Drainage outlet. It is convenient
to lead the drain pipe to a natural
drain by a siphon. If it is not possible,
a minimum of a 300 mm gravel layer,
shall be enough.

4- Control panel and features

- Waterproof metal case, epoxy paint.
- Measures: 400 x 400 x 200 mm
- Supply 230 V
- Maximum capacity up to 5 bollards
- 24V, power supply, circuit breaker, programmable automaton, remote control.
- Vehicle detector with power fail function.
- Funticon selector (manual-automatic)
- Optional: Wifi
- Lock with key

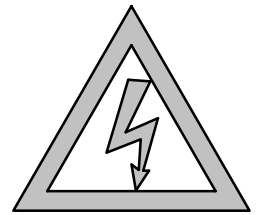

Electrocution



5- Magnetic Loops

The end of the loop must be braided at 20 crossings by meter approx., and take them to the box, connecting both ends in the terminals marked as braided loop in the terminal block of connections.

Towards main cabinet tubed in 25 mm tube corrugated, no type of tube should go wiring, it is recommended not to cross or vehicular towards the frame with pipes containing wiring under tension.

The two ends or tie tails must go braided between yes until box maneuvers

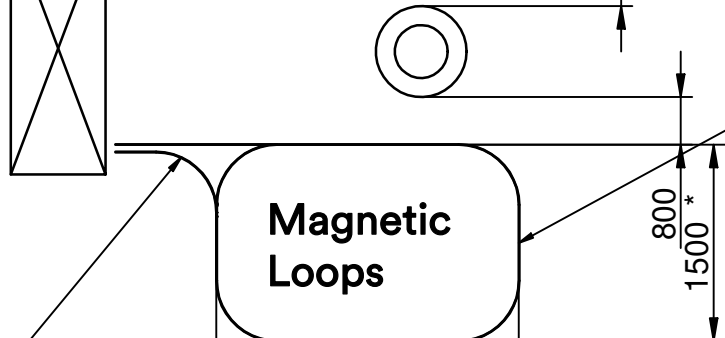
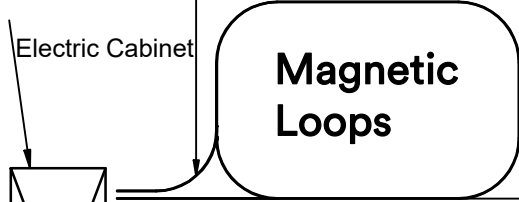
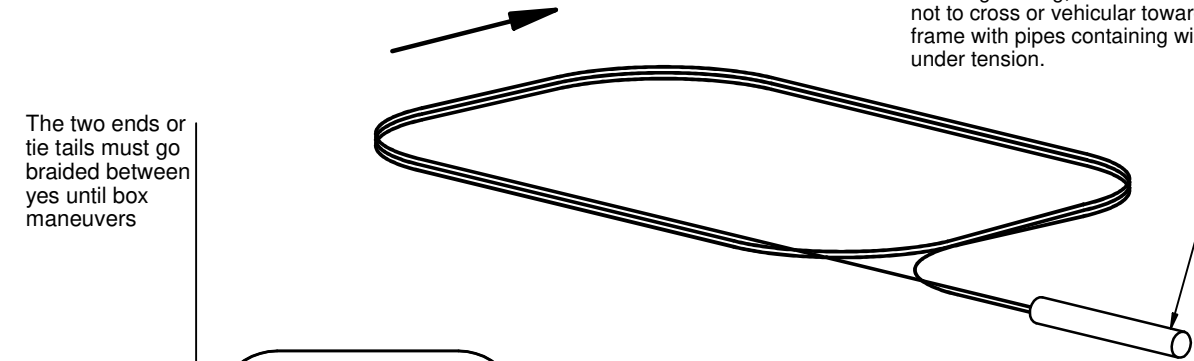

*Minimum recommended measures should be the ones that better adapt and cover the access area. They also must allow the bollard to be seen if the vehicle is in the inside of the safety loops.

The length of the loop is determined, that from point "A" allow see clearly that the bollards have already reached the position of bollard down.

The cut will be filled with fluid cement, resin or sikaflex 221

The two ends or tie tails must go braided between yes until box maneuvering

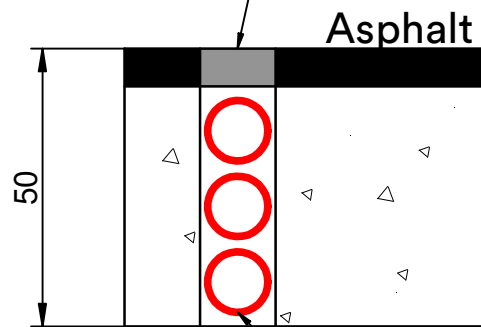
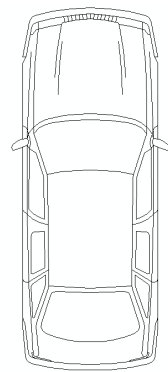

3 turns in 1,5 mm cable min. recommended 2,5 for 7 m2 of loop perimeter.

Spiral calculation table

perimeter	laps
De 1 a 4 m2	De 4 a 8
De 4 a 8 m2	De 3 a 4
De 8 a 16 m2	De 2 a 3
+ de 16 m2	De 1 a 2

The quality of the cable used for the loop is decisive in the duration and life of the system. Its external protection should be able to withstand the aggressions of the environment especially moisture, to prevent earth leakage, as well as the chemical aggressions of the asphalt itself, cement etc...

6- Operation and commissioning

Function selector S1. Only for positive safety bolts, not included in the system of safety bollards and is bollards without magnetic loop with manual operation.

Position

Operation in automatic mode

With luminous crown traffic light function

S1 top position selector

- **Start of the system:** when the bollard is at a lowered position, the luminous crown is in green. After the vehicle has passed, the bollard will start rising, elapsed between 10-12 seconds, provided there is no vehicle inside the perimeter of the safety ties. It will provide a notice cycle of 3 second during which, the crown will show a flashing red light. Once the bollard is in rising position, the red flashing will stop and will remain fixed red.

- **Vehicle safety:** if a vehicle invades the safety zone during the rising procedure, the bollard will stop the ascent (provided a safety loop has been installed). It is not advisable to park any vehicle inside the safety area for more than 3 or 4 minutes. The security is based on metal mass (vehicle, motorcycles, and even bicycles). After the 3 to 4 minutes, the bollard will try to rise again and will only complete the rising if the area has been cleared, otherwise, it will remain in a lowered position.

- **People safety:** (optional): if the order to rise is given when there is a person or an object of above 20 kgs placed on top of the bollard, the bollard will not rise. It will stay in the lowered position during 10 seconds, after which, it will start the rising process again. If the person or the object has not been cleared, it will try again a total of 3 times. After these 3 times, the bollard will remain in the lowered position for 3 minutes providing enough time to clear the area. This is only where the safety people feature is being activated.

S1 central position selector

In this position, the bollard provides the same performance as in top position selector, but there is one difference. When the bollard is in rising position, the red luminous crown will either switch off within 30 seconds the operation is finalized or the light will decrease its intensity (depending on the installation choice). By default, it will turn off after that time and it will only be turned on again once a vehicle has reached the safety area. At that moment, the red flashing of the luminous crown will start.

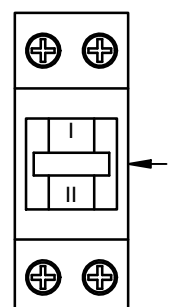
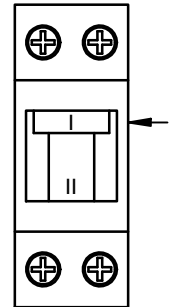

6- Operation and commissioning

Operation in manual mode (step by step)

With luminous crown traffic light function

S1 selector lower position

When the bollard is in the lowered position, it will not start any operation until it receives an order that can be given by a remote control, a proximity card, TAG, etc. Prior this order, the bollard will be in the lowered position, the green luminous crown will be on and there will be no vehicle inside the safety area (provided the loops are installed). When the order is given, the bollard will start the warning cycle for a period of 3 seconds. At this moment, the crown will show a flashing red light, indicating that the rising is imminent. During the rise, the crown will feature a fixed red light. The rising process can be interrupted by pressing the button in the remote control or passing the card again.

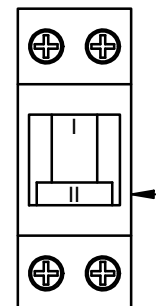

- **Vehicle safety:** if a vehicle invades the safety zone during the rising procedure, the bollard will stop the ascent (provided a safety loop has been installed). It is not advisable to park any vehicle inside the safety area for more than 3 or 4 minutes. The security is based on metal mass (vehicle, motorcycles, and even bicycles). After the 3 to 4 minutes, the bollard will try to rise again and will only complete the rising if the area has been cleared, otherwise, it will remain in a lowered position.

- **People safety:** (optional): if the order to rise is given when there is a person or an object of above 20 kgs placed on top of the bollard, the bollard will not rise. It will stay in the lowered position during 10 seconds, after which, it will start the rising process again. If the person or the object has not been cleared, it will try again a total of 3 times. After these 3 times, the bollard will remain in the lowered position for 3 minutes providing enough time to clear the area. This is only where the safety people feature is being activated.

7- Notices of possible failures

Symptom	Cause	Effect	Action
The bollard reaches the maximum height, and goes back down, repeating it for 3 times it stays down and does not go up. If the tension is removed the system is restored and the three cycles are repeated again. When it reaches the top, the X3 input in the automaton does not light up, the detector bolts up.	Bollard reading failed in the up position, the system does not know that the bollard has reached the top.	1- Dirt that prevents reaching the top of the bollard, or final race failure, for safety the bollard will remain in the down position.	1- Clean remains of sand, mud, etc... 2- Replace end of career detector.
The bollard is in the down position and with rapid flashing in red and changes to green 3 successive times, with the same behavior after 3 minutes.	*People or obstacles safety pressure switch failure.	1- Dirt or obstacle that prevents raising the bollard. 2- Strong blow causing a forced slip, firing safety by obstacle. 3- Pressure switch failure.	1- Inspection and cleaning of debris or obstacles that hinder the normal rise of the bollard. 2- Replace pressure switch and adjust.
When the bollard is in the up position and it descends without starting the engine, the crown is flashing red.	1- Solenoid valve failure. 2- Oil leak.	1- Particle or impurity inside the valve that prevents its closure. 2- Failed valve. 3- Oil leak in hydraulic system.	1- Replace solenoid valve. 2- See oil level, check for possible leaks.
When the bollard is in a stand-up position and the crown lights in flashing red.	Bollard reading failed above, the system does not recognize in which position the bollard is stopped.	1- Dirt that prevents reaching the top, or final race failure.	1- Clean remains of sand, mud ... etc, 2- Replace detector.
Bollard stays down completely and the crown lights green, no X2 input is indicated, pylon detector below.	Bollard reading failed below, the system does not recognize in which position the pylon is stopped.	1- Dirt that prevents reaching the top, or final race failure.	1- Clean bottom pylon drawer. 2- Replace the end of the race.
The bollard does not rise staying down with a green crown, and the exit is switched on in an automaton (Y3-Y5)	The bollard has made three attempts to climb by not finding the bollard signal above (X3)	1- Bollard does not rise. 2- If we remove the tension (reset), the bollard will try to rise again and if she still does not find a limit switch up (X3) she will try 2 more times, staying down again.	1- Clean debris from sand, mud, ... etc, 2- Replace end of race detector.
The bollard does not rise staying down with green crown, and automaton does not turn on the entrance (X4)	* People or obstacles safety pressure switch failure.	1- Dirt or obstacle that prevents raising the bollard. 2 - Strong blow causing a forced slip, firing safety by obstacle. 3- Pressure switch failure.	1- Inspection and cleaning of debris or obstacles that hinder the normal rise of the bollard. 2- Replace pressure switch.
The bollard does not rise staying down with a green crown, and the entrance (X5) does not turn on in an automaton.	Magnetic loop failure for vehicle detection.	Presence of metallic mass on the loop. Loop failure or breakage. Faulty detector.	1- Remove obstacle or metal mass on the loop (s). 2- Repair spiral or loop. 3- Replace detector. 4- Reset detector.
The bollard starts the ascent stage and disappears the entry (X5) of the automaton, lowering the bollard again, and without the presence of a vehicle on the turns or loops.	Magnetic loop failure for vehicle or metal mass detection.	One of the turns or both, have been placed very close to the pylon and they detect moving metal mass (vehicle)	1- Separate the turns of the bollard should be 800 mm from the body of the bollard. 2- Reset detector.

Status of the necessary indications of the automaton in raised position.
Leds on: **X0** = Security - **X3** = Pylon up - **X4** = People security * - **X5** = Safety loop

Status of the necessary indications of the automaton in the lowered position.
Leds on: **X0** = Security - **X2** = Pylon down - **X4** = Security people * - **X5** = Safety loop

* Only in installations with pressure switch installed for personal safety, in the standard version the pressure switch is optional.

8- General warnings for use

General warnings for use

- This operation manual is intended for the installer, who will have to read and understand the commissioning of the equipment.
- The electrical supply that feeds the control panel must be protected by a device differential 40 / 30 mA.
- Installation, electrical connections and adjustment settings must be made in accordance with the regulations in force in each country where they are installed.
- Read the instructions carefully before beginning the installation of the equipment.
- The bollards are designed and programmed for autonomous and automatic operation.
- In the event of any operational problem, the bollard will remain in the lowered position and signaling said error with intermittency in red, as long as it is not due to the accidental impact of a vehicle and the bollard can not go down. This is provided the bollard is in positive safety mode.
- Do not open or manipulate the bollard if it is not disconnected from the power supply. This operation must be only carried out by qualified personnel.
- The manufacturer of the bollard is not responsible of the breach of any of the warnings provided in this manual or of an inadequate use for which it has been designed.
- The bollards are obstacles that are in our way, and as such, the users who circulate on the bollards with their vehicles they should do so as long as the bollard has been hidden totally in the subsoil, once the bollard is completely lowered, and its crown indicates it in green, the user will have ten seconds (adjustable time) to approach it, once the vehicle is within the security perimeter, it can be passed on it quietly, being the vehicle on safety, and even on the bollard, it will never rise.
- The installations must feature the necessary devices to ensure the safety of pedestrians and vehicle.

Basic recommendations

- Move around the area with slow speed.
- The installations must feature the necessary devices to ensure the safety of pedestrians and vehicle.
- Do not overpass the bollard when the crown is in red.
- Overpass the bollard only when the crown is in green.
- Remember that the bollards do not hit the vehicles. If we drive at a slow speed we will give them enough time to reach the lowered position. If the speed is too fast, then the possibility of hitting the bollard increases.

9- Terminal block

Electrical connections for one control unit

Wiring diagram Bollard
H275AV

Form the Bollard

From the Terminal Block

- 1 Neutral Mode
- 2 Raise Mode
- 3 Descend Mode
- 4 Solenoid (electrovalve)
- 5 Solenoid
- 6 FC lower limit switch
- 7 FC lower limit switch
- 8 FC upper limit switch
- 9 FC upper limit switch
- 10 Neutral Led Ring
- 11 Ring Led Red
- 12 Ring Led Green
- 14 Traffic light Red
- 15 Twisted Loop
- 16 Twisted Loop

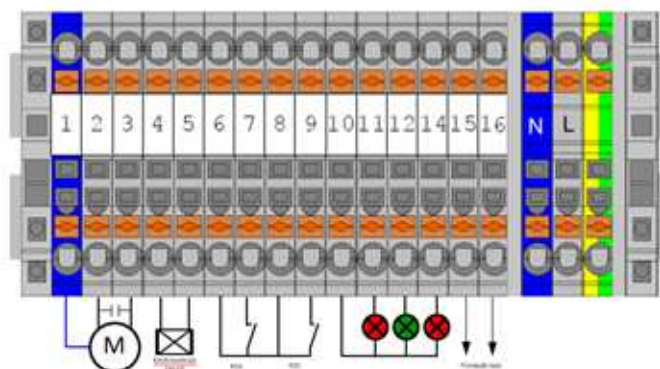

Note: 13
Leave free blue ring, do not connect.

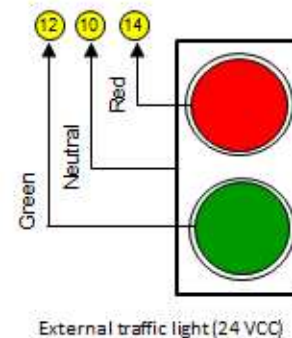
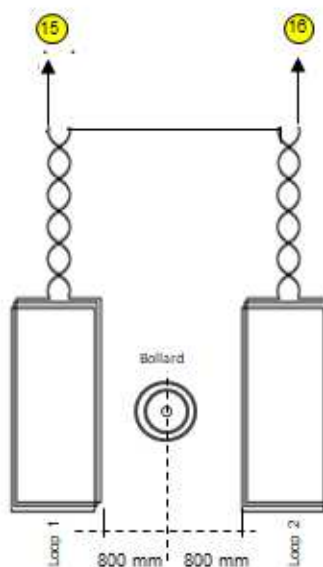

10- CE certificate

DECLARATION OF CONFORMITY FOR MACHINES

Manufacturer: BENITO URBAN, S.L.U.

Adress: Calle lleida, 10 08500 -Vic-Barcelona

Declares: The bollard model H275AV 4mm - H275AV 8mm

It has been manufactured to be incorporated into a machine or to be assambled with others machinery for manufacturing a machine in accordance with directive 2006/42/CE and meets the essential safety requirements of the following EEC directives.

2006/95/CE Low voltage directive

2004/108/CE Electromagnetic compatibility directive

It also declares that it is not allowed to operate the machinery until the machine in wich it should be incorporated or of wich it will be a component has been identified and declared in accordance with the conditions of the directive Directiva 2006/42/CEE as well as its subsequent modifications.

DECLARATION OF CONFORMITY FOR MACHINES

Manufacturer: BENITO URBAN, S.L.U.

Adress: Calle lleida, 10 08500 -Vic-Barcelona

Declares: Electric switchboard

Meets the essential safety reuirementes of the following directives CEE

2006/95/CE Low voltage directive

2004/108/CE Electromagnetic compatiblility directive

Note:

This product has been tested in a typical homogeneous configuration.

11- Warranty

- Warranty terms and conditions for BENITO products

Our products have been subjected to rigorous quality controls before leaving the production chain, as well as functionality tests and use for restriction, regulation and access control, these being the environments for which they have been designed. However, if any problem arises, please read these warranty conditions carefully

The guarantee certificate issued by BENITO guarantees the quality of the product that it covers, under the legally established terms, for a period of two years in the control panel and one year in the bollard and / or bollard including hydraulics, from the delivery date there of taking the invoice date as valid, if the delivery is prior to the final issuance of the invoice itself, the guarantee will start counting from said delivery, appearing on the same invoice.

Exclusions

Deficiencies caused by negligence, shock, use, maintenance or improper handling inappropriate tension are not included, improper installation, nor materials subject to wear due to normal use; as well as accidents, natural disasters or any other cause beyond the control of BENITO.

- Improper handling, improper use, negligence, overload or abandonment of the device, current instability, power surges, faulty installations and other external causes that are not attributable to the manufacture and quality of the product.
- Damage caused by breaks, blows or scratches in any part of the bollard / bollard that form its assembly for the control of access.
- Damage caused during transport, by impacts or atmospheric actions or any other cause of force majeure or other than attributable to the quality of the device.
- Repairs or repair of the device by personnel not expressly authorized by BENITO. If this is the case, the warranty it will be invalidated at that moment.
- The installation or use of the product in a manner not in accordance with the technical or safety standards in force at this time.
- The expenses derived for the displacement of technical personnel of BENITO, to the location of the bollard / bollard that the client indicate.
- The shipping costs of any of the parts, pieces, etc... That must be sent to BENITO for repair as well as its resend that must agree / manage with BENITO prior to shipment.

Duration and scope

- For two years in the box and one year at the pylon, BENITO guarantees the product, against any manufacturing defect that affects its smooth operation for which it has been designed.
- In case of any anomaly detected, the content of the section via complaint must be followed by calling the referenced telephone and informing BENITO, the incidence, evaluating this by the technical department, will proceed to send the replacement / replacement as well as the instructions necessary for its correct replacement, as well as the direct telephone attention with our S.A.T., the cost of replacement / repair labor or displacement of personnel from BENITO (see exclusions), if required by the property or client, this possibility should always be agreed in advance with BENITO.
- The lack of maintenance of the device as a whole, or that it has been performed incorrectly and improperly against the instructions provided by BENITO.
- Each and every one of the spare parts / spare parts, necessary for the repair of the bollard / bollard during BENITO's warranty period they will be sent to the place indicated by the customer for replacement. (Shipping costs will be borne by the customer).
- For the validation of this guarantee, the previous display of the purchase invoice will be an essential requirement.

Claim route

- The purchaser of the machine must contact BENITO, through the telephone number 938521000, for the purpose of putting in knowledge of your lack of conformity about the anomaly detected, or the operation of the device itself.